

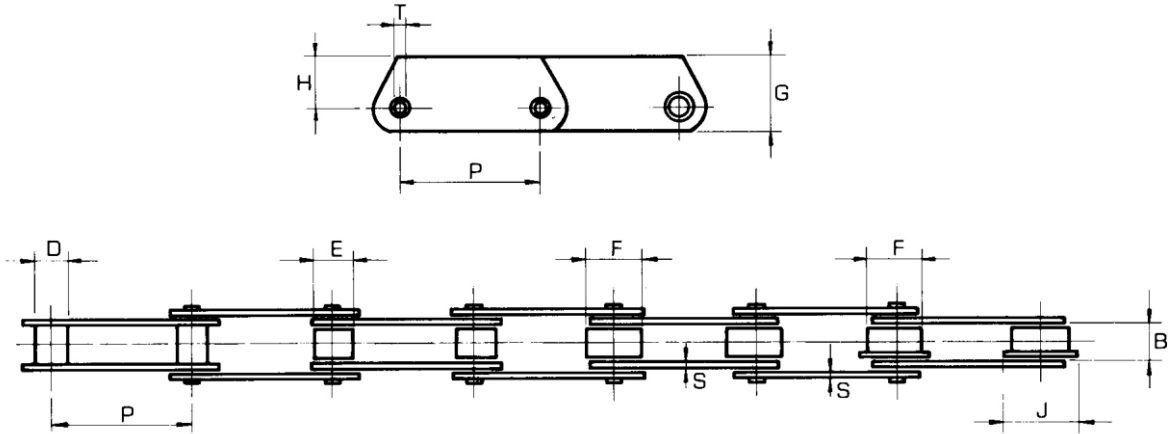

CADENAS TRANSPORTADORAS

ISO / R1977 - DIN 8168
DE EJES HUECOS Serie MCT



| Ref. Cadena | Carga Rotura Kp. | PASO P | | CADENAS BRIDAS ALTAS Serie MCT | | | | | | | | | | | | | | | | |
|----------------|------------------------|-----------|-----|--------------------------------|----------|-----------|----------|---------------|------|--------|----|--------|-------------------|-----------|-----------|--------------------------------------|------|----|-----|------|
| | | | | Ancho Interior | Ø eje | Ø Casq | RODILLOS | | | BRIDAS | | | Ø Eje Hueco | ANCHO | | Supe r- ficie Artic. cm2 | | | | |
| | | | | | | | Peq | Sali- ente | Pest | Ancho | | Grueso | | L Máx. | K Máx. | | | | | |
| | | | | B | C | D | E | F | J | G | H | S | T | | | | | | | |
| MCT-28 | 2.800 | 63 | 80 | 100 | 125 | 160 | 200 | 20 | 13 | 17,5 | 25 | 36 | 42 | 35 | 22,5 | 3,5 | 8,2 | 42 | 3,5 | 3,64 |
| MCT-56 | 5.600 | 80 | 100 | 125 | 160 | 200 | 250 | 24 | 15,5 | 21 | 30 | 50 | 60 | 50 | 32,5 | 4 | 10,2 | 48 | 5 | 5,11 |
| MCT-112 | 11.200 | 100 | 125 | 160 | 200 | 250 | 315 | 32 | 22 | 29 | 42 | 70 | 85 | 70 | 45 | 6 | 14,3 | 67 | 7 | 9,9 |
| MCT-224 | 22.400 | 160 | 200 | 250 | 315 | 400 | 500 | 43 | 31 | 41 | 60 | 100 | 120 | 100 | 65 | 8 | 20,3 | 90 | 9 | 18,5 |