

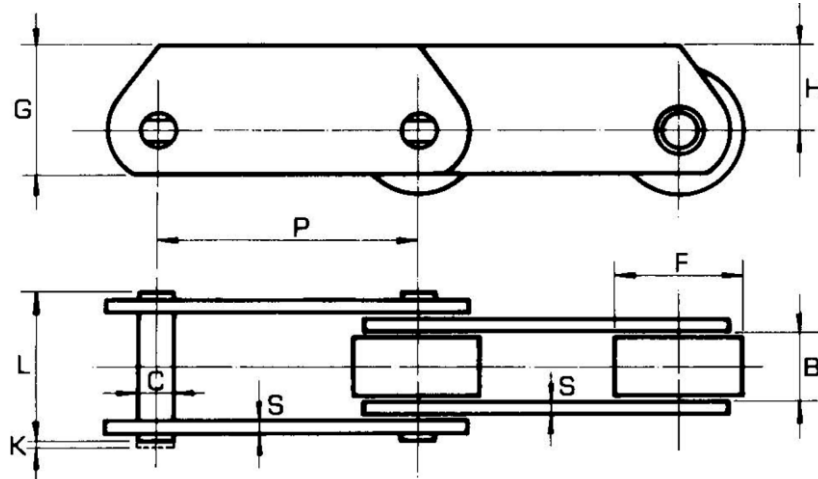

CADENAS TRANSPORTADORAS DIN 8165 DE BRIDAS ALTAS Serie FVT



Ref. Cad.	Carga Rotura Kp.	PASO P	CADENAS LISAS Serie FVT													
			Ancho Interior	Ø eje	Ø Casq	RODILLOS			BRIDAS			ANCHOS		Superficie Articul. cm ²		
						Peq.	Salien	Pest.	G	H	S	L max	K max			
															F	F ₁ /J
FVT-40	4.000	63 80 100 125 160	18	10	15	20	32	40/48	35	22	3	37	5	2,5		
FVT-63	6.300	80 100 125 160 200	22	12	18	26	40	50/60	40	25	4	46	6	3,7		
FVT-90	9.000	80 100 125 160 200 250	25	14	20	30	48	63/73	45	27,5	5	53	6,5	5		
FVT-112	11.200	100 125 160 200 250 315	30	16	22	32	55	72/87	50	30	6	63	7	6,8		
FVT-140	14.000	100 125 160 200 250 315	35	18	26	36	60	80/95	60	37,5	6	68	8	8,6		
FVT-180	18.000	100 125 160 200 250 315	45	20	30	42	70	100/120	70	45	8	86	8,5	12,3		
FVT-250	25.000	125 160 200 250 315 400	55	26	36	50	80	125/145	80	50	8	97	10	18,7		
FVT-315	31.500	160 200 250 315 400	65	30	42	60	90	140/170	90	55	10	119	12,5	25,8		
FVT-400	40.000	160 200 250 315 400	70	32	44	60	100	150/185	90	55	12	130	13	30,7		
FVT-500	50.000	200 250 315 400 500	80	36	50	70	110	160/195	100	60	12	143	15	38,2		
FVT-630	62.000	200 250 315 400 500	90	42	56	80	120	170/210	120	70	12	153	18,5	48		

- Otros pasos intermedios se fabrican bajo demanda.